

Control Method for Low Oxygen Concentration in Reheating Furnace

HENG-HSING CHENG, YUAN-LIANG HSU, CHAO-HUA WANG*,
FU-YUAN HSIA** and TUNG-TSAI OU**

Iron and Steel Research & Development Department
**New Materials Research & Development Department.*
***Rolling Mill Department II*
China Steel Corporation

The reheating furnace consumes most of the energy and produces high amounts of carbon dioxide in the hot rolling process. The oxygen concentration in the furnace atmosphere is very important because too much oxygen will cause greater fuel consumption and will induce more scale on the slab surface and more nitrogen oxides in the combustion gas. Proper control of the oxygen concentration enables the furnace to attain a better production cost performance in energy consumption, slab scale loss and NOx emission. There are two sources of oxygen in the furnace atmosphere. One is the combustion air supplied to the burner and the other is the outside air infiltrated into the furnace during door opening. In this study, a control technology was proposed to inhibit the air infiltration and to minimize the oxygen concentration in the furnace atmosphere by controlling the furnace pressure and combustion air using a prediction method, which could estimate the influence from the variation in combustion loading based on the state of change in the control loop. The proposed control method has been implemented in the reheating furnaces of No.1 and No.2 hot strip mill in China Steel Corporation. The results reveal that the control method could inhibit the air infiltration significantly through a decrease in the furnace temperature drop after the door opening. Moreover, the oxygen concentration in the furnace atmosphere could be stably minimized based on the better control performance. Also, the results of experiments demonstrated that this method reduced the fuel consumption of the furnace, the scale loss of the heated slab and thermal NOx emission.

Keywords: Furnace pressure, Oxygen concentration, Air-to-fuel ratio, Fuel consumption, Slab scale loss

1. INTRODUCTION

In the hot strip mill, slabs are heated above 1150°C for the subsequent rolling process, so the low-temperature slabs are pushed into the reheating furnace from the charging side and heated gradually via the pre-heating zone, heating zone and soaking zone and extracted at the discharging door, as shown in Fig.1. Oxygen is an

essential element for the combustion reaction in the reheating furnace, though the oxygen in the furnace also participates in some of the reactions, including the formation of nitrogen oxides (NOx), or oxide layer on the surface of the slab (see Fig.2). Excess oxygen in the furnace not only increases the energy consumption and slab scale, but also increases the slab scale and thermal NOx, and other negative effects suppressed during

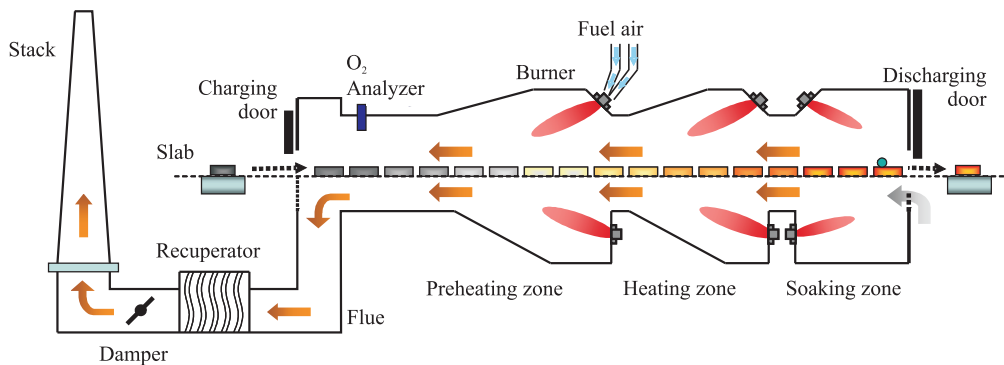

Fig.1. Reheating furnace in hot strip mill.

oxygen deficiency. The best situation is to ensure the complete combustion of the fuel under the premise of minimizing the residual oxygen or, in other words, to maintain a low level of oxygen concentration in the exhaust gas. On the other hand, in the high-temperature furnace area, such as the heating zone and soaking zone, to supply deficient oxygen can effectively slow down the oxidation rate of steel slabs, so it is necessary to ensure that all the residual fuel is burnt in the downstream zone. Fuel consumption and slab scale loss are the major costs in the hot rolled strip or plate production line in addition to the material cost. Generally, in the reheating furnace the fuel consumption per ton of steel is about 280 to 320×10^6 calories, and the oxide scale causes a slab weight loss about 0.6 to 1% . Therefore, the stable control of the oxygen in the furnace atmosphere and the maintenance of a low oxygen concentration in the exhaust gas are the means to reduce fuel consumption and scale loss.

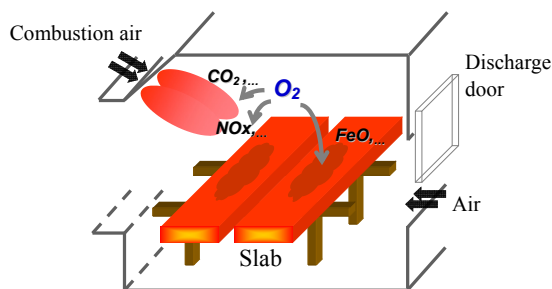

Fig.2. Reaction of oxygen in the slab reheating furnace.

There are two sources for the oxygen in the furnace atmosphere. One is the combustion air supplied to the burner and the other is the outside air inhaled into the furnace during the opening of the discharging door. Both result in a variation of the oxygen concentration in the furnace atmosphere. Every few minutes, the discharge door is opened briefly to extract the heated slabs. Since there is a difference in the ambient temperature inside and outside the furnace, there exists a vertical pressure drop. The vertical pressure drop causes negative pressure at the bottom of the furnace while the door is opening and the outside air is inhaled into the furnace. Therefore, the furnace temperature in the soaking zone is significantly decreased and the oxygen concentration of the exhaust gas appears to peak after the door is opened, as shown in Fig.3. Figure 3 also reveals that air inhalation is different each time because of the different peak value of oxygen concentration.

Besides the air infiltration, the fluctuation of fuel composition also disturbs the oxygen concentration. The unit volume of air required for complete combustion of fuel is called the theoretical air consumption coefficient and is based on the fuel

composition. For example, the coefficient for coke oven gas (C.O.G.), which is usually used as the source of the heating fuel in the reheating furnace, is about 4.2 . The furnace temperature is controlled by adjusting the fuel flow supplied to the burners and the air flow needed for complete combustion according to the coefficient. However, it is difficult to control the composition of C.O.G. precisely. Figure 4 shows that the calorific value of C.O.G. changes in the range of 4080 to 4320 kcal/m³. If the fuel heating value changes, the amount of air needed for combustion of fuel may be excessive or inadequate, resulting in a variation of the oxygen concentration in the exhaust gas.

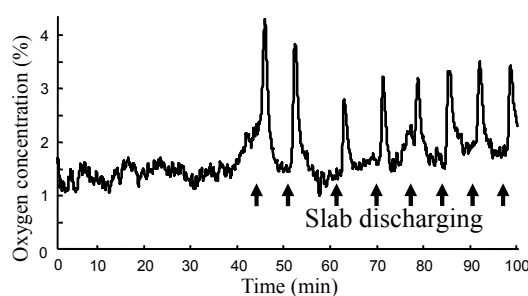

Fig.3. Air inhalation during discharge door opening.

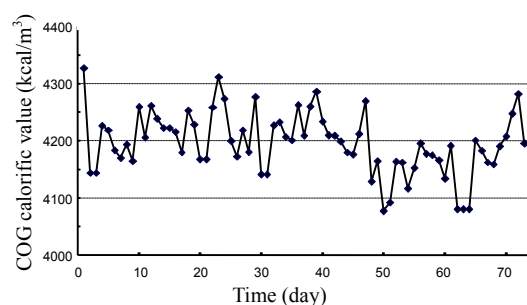

Fig.4. Daily change of C.O.G. calorific value.

In general, oxygen analyzers may be installed in the roofs of the preheating zone, heating zone and soaking zone to measure the oxygen content in the furnace atmosphere and used to control the oxygen concentration of waste gas by automatically adjusting the air-to-fuel ratio (A/F ratio) in every zone⁽¹⁻²⁾. Some studies proposed other designs of oxygen feedback control with time delay compensation⁽³⁾ or used some advanced control techniques such as fuzzy-PID control⁽⁴⁾. However, in most furnaces of China Steel, the oxygen analyzer can easily fail in high temperature surroundings such as those in the heating zone or soaking zone and the sampling tube can easily become clogged because of sulfide deposition. So the feedback control of oxygen concentration cannot be used in every furnace zone at China Steel. However, at higher temperatures, the oxidation rate of the slab in the fur-

nance may increase almost exponentially⁽⁵⁻⁶⁾, so reducing the oxygen content in the high temperature zone can effectively reduce the slab scale as mentioned above. In practice, the combustion air supplied to the heating zone and soaking zone may be inadequately controlled by manually adjusting the A/F ratio less than 1.0 (with A/F ratio larger than 1.0 at the preheating zone). Therefore, the measured oxygen concentration at the heating zone and soaking zone would be zero and cannot be used to control the A/F ratio automatically. Otherwise, some studies proposed that real-time measuring of the calorific value of C.O.G. to adjust the A/F ratio dynamically in accordance with an empirical formula to compensate for the effect of changes in caloric value⁽⁷⁾. However, this method is a kind of feed-forward control that is not able to overcome other disturbances such as air inhalation.

Because there is no feasible and stable method for oxygen control in the high furnace atmosphere, additional fuel consumption and scale loss result. In this research, a control method for low oxygen concentration of waste gas in a reheating furnace is proposed. First, a discharge prediction control of the furnace pressure was developed to predict quantitatively the level of air inhalation within a few seconds after the discharge door is opened. Then the furnace pressure can be immediately controlled during the whole period of door opening (about 45 seconds) to reduce the air inhaled into the furnace. Second, a new control architecture for automatically adjusting the A/F ratio was proposed to stably maintain the waste gas at a low oxygen state. The new control architecture includes a theoretical zone A/F ratio calculation by considering the residual fuel gas or oxygen from the upstream zone, the flow compensation when the burner is supplied

with excess air, and finally a feedback control based on the actual oxygen concentration measured at the preheating zone roof near the charging door (a low-temperature area in the furnace, where the reliability of the oxygen analyzer is greatly enhanced) to correct any error from the theoretical mode.

The proposed control method has been implemented in the reheating furnaces of No.1 and No.2 hot strip mills at China Steel Corporation. The results reveal that the control method could inhibit the air infiltration significantly based on the decreasing of the furnace temperature drop after the door opening. Additionally, the oxygen concentration in the furnace atmosphere could be stably minimized based on the better control performance. Also, the results of experiments demonstrate that this method improves the uniformity of slab temperature and reduces the fuel consumption of the furnace, the scale loss of heated slab and thermal NOx emission.

2. EXPERIMENTAL METHOD

The method proposed in this study for controlling the oxygen concentration in waste gas is exhibited in Fig.5. The method includes two parts: the discharge prediction control of the furnace pressure; and the automatic air-to-fuel ratio control with the estimation of the zone oxygen concentration.

2.1 Discharge Prediction Control of Furnace Pressure

Because the transient response of the temperature field and flow field in the reheating furnace is complex when the discharge door is opened, it is difficult to decouple the governing equation of furnace pressure by the theoretical analysis. Yet any change of the flow field will eventually be reflected in changes of the

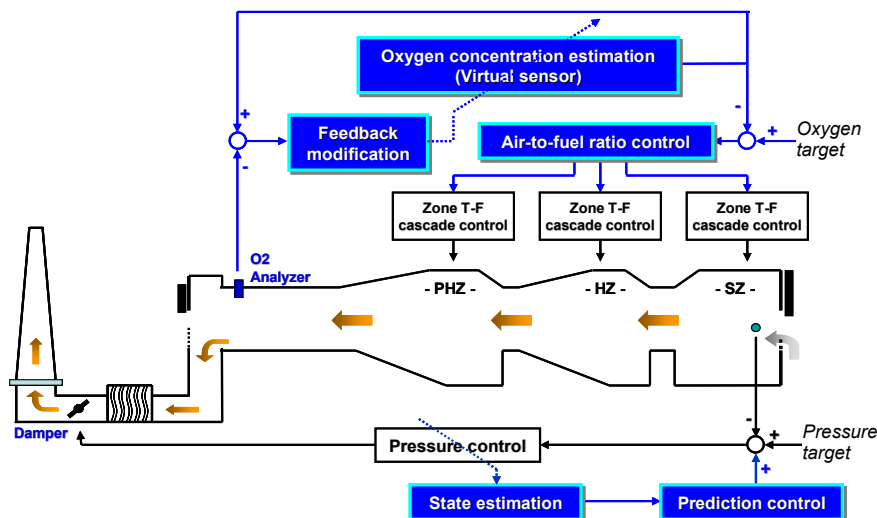

Fig.5. Low oxygen control of reheating furnace.

equilibrium state of the furnace pressure control. After the study of large amounts of data through statistical analysis the characteristics of the pressure changes during the opening of the discharge door were determined, as shown in Fig.6 and Fig.7. The temperature drop at the soaking zone after discharging door is opened can indicate the air inhalation as a quantitative index. The data shown in Fig.6 reveals that the temperature drop is quasi-linear relative to the average error of furnace pressure control during whole period of discharging. Also, it was found that the trend of the equilibrium state change in the furnace pressure control is consistent throughout the whole period of discharging, so that the output change in the furnace pressure control loop within 5 seconds after door opening has a negative correlation with the average error of pressure control, as shown in Fig.7. The control output was used to adjust the flue damper opening.

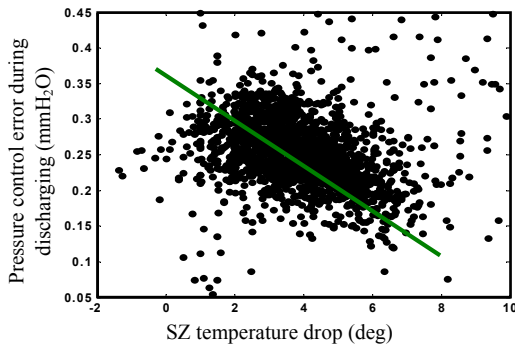

Fig.6. Quasi-linear relation between temperature drop at soaking zone and furnace pressure. control error during discharging.

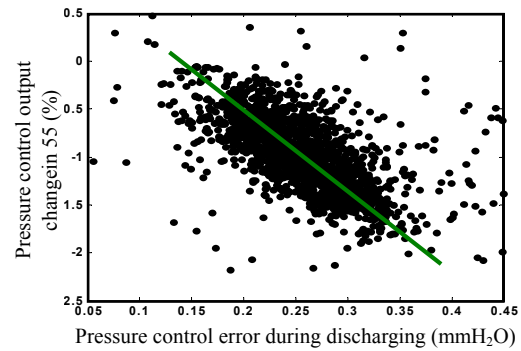

Fig.7. Quasi-linear relation between pressure control error during discharging and control output change in 5s.

On the basis of the above-mentioned findings, the discharging prediction control was designed in this study to automatically adjust the furnace pressure. The control diagram is exhibited in Fig.8. Basically, the furnace is kept at a low positive pressure, i.e. 0.2mm H₂O, and then starts to dynamically adjust the pressure before the opening of the discharging door. Due to the long distance from pressure measurement position to the flue damper, the response of the furnace pressure control is slow (about 10 seconds). So, about 30 seconds before opening the door, the furnace pressure has to be raised by following the pre-designed pattern. The prediction control is then started 5 seconds after door opening. The algorithm of the prediction control is to change a preset temperature drop in the expected furnace pressure control error first, in accordance with the linear regression equation in Fig.6. Then, the output increment of the pressure PI controller (Proportional-Integral controller) within 5 seconds after each door opening is used to estimate the average error of the furnace pressure control during the whole discharging

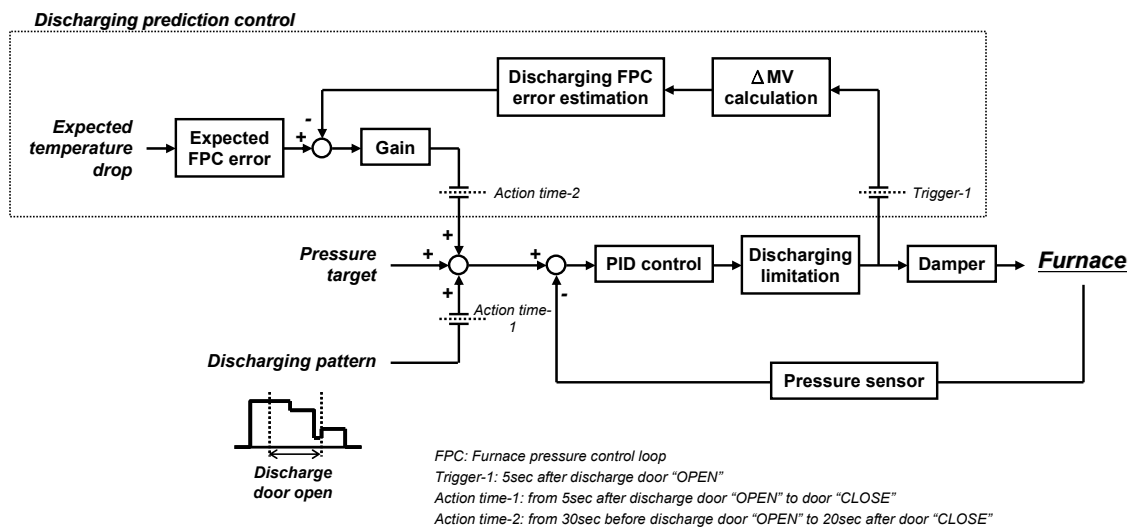

Fig.8. Discharging prediction control of furnace pressure.

period according to the linear regression equation in Fig.7. The difference between the estimated error and the expected error can be used to adjust the control target of the furnace pressure directly until the discharging door is closed. So, the correction of furnace pressure by the prediction control is different and can control the air inhalation during each period of slab discharging.

2.2 Automatic Air-to-Fuel Ratio Control

In general, the reheating furnace may be split into multiple independent temperature control zones to gradually heat slabs to a set temperature. The gas in the furnace flows from the soaking zone to the preheating zone, so the residual fuel gas or air from the upstream zone may influence the combustion reaction in the current zone, as shown in Fig.9. For example, if the supplied air soaking zone is inadequate, i.e. the air-to-fuel (A/F) ratio of the soaking zone is set to 0.9, it means that about 10% fuel gas may not be burnt and flow to its downstream zone (the heating zone.). The new control method is based on the expected air-to-fuel ratio in every zone to re-calculate the required zone A/F ratio by considering the residual fuel gas or air from the upstream zone. The algorithm is shown in Equation 1,

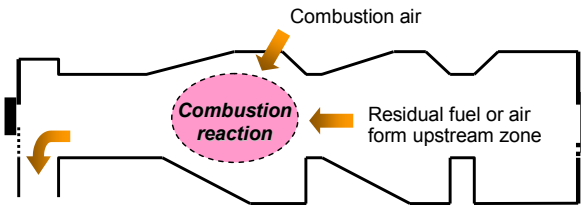

Fig.9. Illustration of residual fuel gas or air form up-stream zone.

$$\frac{\dot{V}_{a_i}}{\dot{V}_{f_i}} = \frac{\dot{\tilde{V}}_{a_i} + \dot{\tilde{V}}_{a_{i-1}}}{\dot{\tilde{V}}_{f_i} + \dot{\tilde{V}}_{f_{i-1}}} = \alpha_i \eta \dots\dots\dots (1)$$

where \dot{V}_{a_i} and \dot{V}_{f_i} are the volume flow of air and fuel gas in the i^{th} zone; $\dot{\tilde{V}}_{a_{i-1}}$ and $\dot{\tilde{V}}_{f_{i-1}}$ are the residual air and fuel gas from the upstream zone; $\dot{\tilde{V}}_{a_i}$ and $\dot{\tilde{V}}_{f_i}$ are the supplied air and fuel gas of the burner; α_i is the expected zone air-to-fuel ratio and η is the theoretical air consumption coefficient of the fuel gas. μ_i is the required air-to-fuel ratio for controlling the supplied air of burner as shown in Equation 2 and it can be expressed as Equation 3, where the residual air or fuel gas are calculated as Equation 4.

$$\dot{\tilde{V}}_{a_i} = \mu_i \eta \dot{\tilde{V}}_{f_i} \dots\dots\dots (2)$$

$$\mu_i = \frac{\alpha_i \eta (\dot{\tilde{V}}_{f_i} + \dot{\tilde{V}}_{f_{i-1}}) - \dot{\tilde{V}}_{a_{i-1}}}{\eta \dot{\tilde{V}}_{f_i}} \dots\dots\dots (3)$$

$$\begin{cases} \dot{\tilde{V}}_{f_{i-1}} = 0, \dot{\tilde{V}}_{a_{i-1}} = (\alpha_{i-1} - 1) \eta \dot{\tilde{V}}_{f_{i-1}}, & \text{if } \alpha_{i-1} \geq 1 \\ \dot{\tilde{V}}_{f_{i-1}} = (1 - \alpha_{i-1}) \dot{\tilde{V}}_{f_{i-1}}, \dot{\tilde{V}}_{a_{i-1}} = 0, & \text{if } \alpha_{i-1} < 1 \end{cases} \dots\dots\dots (4)$$

In the final zone of the flow direction, all fuel gas should be completely burnt to avoid any additional fuel consumption or pollution, so the control target in the preheating zone is the expected oxygen concentration (γ) in the waste gas. The theoretical expression is shown as Equation 5,

$$\gamma(\%) = \frac{21 \times \dot{\tilde{V}}_{a_{PHZ}}}{\dot{\tilde{V}}_{w_{PHZ}} + \dot{\tilde{V}}_{a_{PHZ}}} \dots\dots\dots (5)$$

where is $\dot{\tilde{V}}_{w_{PHZ}}$ is the combustion gas in the preheating zone and is expressed as Equation 6 according to the theoretical combustion gas production coefficient (ζ) and then the expected air-to-fuel ratio can be calculated as Equation 7. Also, the required air-to-fuel ratio in the preheating zone can be obtained by the Equation 3.

$$\dot{\tilde{V}}_{w_{PHZ}} = \zeta (\dot{\tilde{V}}_{f_{PHZ}} + \dot{\tilde{V}}_{f_{HZ}} + \dot{\tilde{V}}_{f_{SZ}}) \dots\dots\dots (6)$$

$$\alpha_{PHZ} = \frac{\gamma \zeta (\dot{\tilde{V}}_{f_{PHZ}} + \dot{\tilde{V}}_{f_{HZ}} + \dot{\tilde{V}}_{f_{SZ}})}{(21 - \gamma) \eta (\dot{\tilde{V}}_{f_{PHZ}} + \dot{\tilde{V}}_{f_{HZ}})} + 1 \dots\dots\dots (7)$$

According to the above-mentioned algorithm the required A/F ratio in each zone can be calculated, so that the actual ratio of air and fuel gas participating in the combustion reaction can meet the expected situation. Besides, additional air is required to ensure combustion efficiency when the fuel flow supplied to the burner is low. The additional air also affects the combustion reaction in the downstream zone, so a compensation method was proposed to compensate for the extra air from the burner. Finally, a feedback control method was proposed to correct the error between the actual oxygen concentration measured in the preheating zone and the estimated oxygen concentration. The estimated oxygen concentration is calculated by the measured flow rates of fuel gas and air in all combustion zones. It is assumed that any variation of the calorific value of C.O.G. results in a percentage change of the theoretical air consumption coefficient ($\eta \Rightarrow (1 + \Delta\eta)\eta$). Substituting into Equation 5, the measured oxygen concentration ($\tilde{\gamma}$) can be expressed as Equation 8. Therefore, the percentage change of the theoretical air consumption coefficient can be estimated as Equation 9 and used to correct the theoretical zone

air-to-fuel ratio and flow compensation via a PI controller. Figure 10 depicts the brief control diagram of the automatic A/F control. To reduce the influence of any time delay from the flow field and measurement response, all data used in the feedback correction was calculated via a window average with the duration of 5 minutes.

$$\tilde{\gamma}(\%) = \frac{21 \times [(\hat{V}_{a_{PHZ}} + \hat{V}_{a_{HZ}} + \hat{V}_{a_{SZ}}) - (1 + \Delta\eta)\eta(\hat{V}_{f_{PHZ}} + \hat{V}_{f_{HZ}} + \hat{V}_{f_{SZ}})]}{\zeta(\hat{V}_{f_{PHZ}} + \hat{V}_{f_{HZ}} + \hat{V}_{f_{SZ}}) + [(\hat{V}_{a_{PHZ}} + \hat{V}_{a_{HZ}} + \hat{V}_{a_{SZ}}) - (1 + \Delta\eta)\eta(\hat{V}_{f_{PHZ}} + \hat{V}_{f_{HZ}} + \hat{V}_{f_{SZ}})]} \quad (8)$$

$$\Delta\eta = \frac{(21 - \tilde{\gamma}) \times [(\hat{V}_{a_{PHZ}} + \hat{V}_{a_{HZ}} + \hat{V}_{a_{SZ}}) - \eta(\hat{V}_{f_{PHZ}} + \hat{V}_{f_{HZ}} + \hat{V}_{f_{SZ}})] - \tilde{\gamma}\zeta(\hat{V}_{f_{PHZ}} + \hat{V}_{f_{HZ}} + \hat{V}_{f_{SZ}})}{((21 - \tilde{\gamma})\eta + \tilde{\gamma}\zeta) \times (\hat{V}_{f_{PHZ}} + \hat{V}_{f_{HZ}} + \hat{V}_{f_{SZ}})} \quad (9)$$

3. RESULTS AND DISCUSSION

The discharging prediction control can predict the level of air inhalation after the opening of the discharging door and automatically adjust the furnace pressure. Figure 11 shows the results of the discharging prediction control. The Figure11(a) shows the phenomenon of temperature drop at the soaking zone after slab discharging without using the prediction control. The temperature drop after each slab discharging is different means that the level of air inhalation is also different. The Figure11(b) reveals that the temperature drop is significantly improved by using the prediction control. The measured oxygen concentration in the waste gas shown in Fig.12 also demonstrates that the air inhalation from the discharging door is decreased.

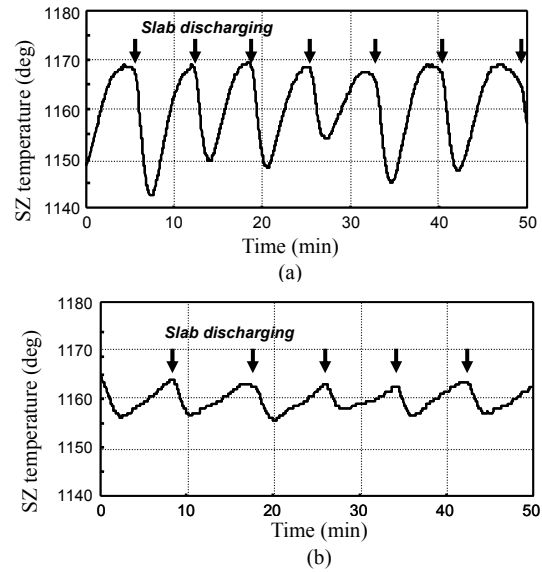

Fig.11. Results of soaking zone temperature (a)without and (b)with discharging prediction control of furnace pressure.

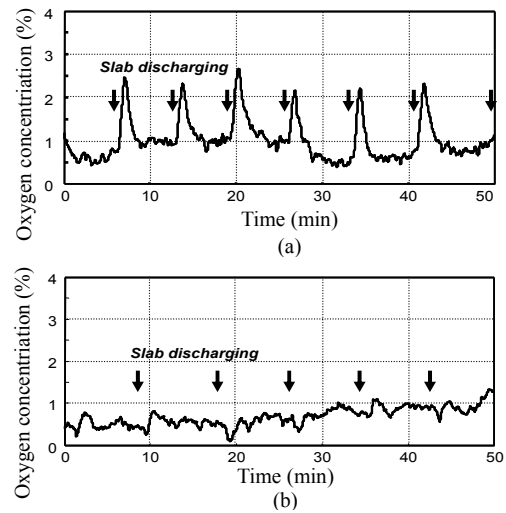

Fig.12. Results of oxygen concentration (a)without and (b)with discharging prediction control of furnace pressure.

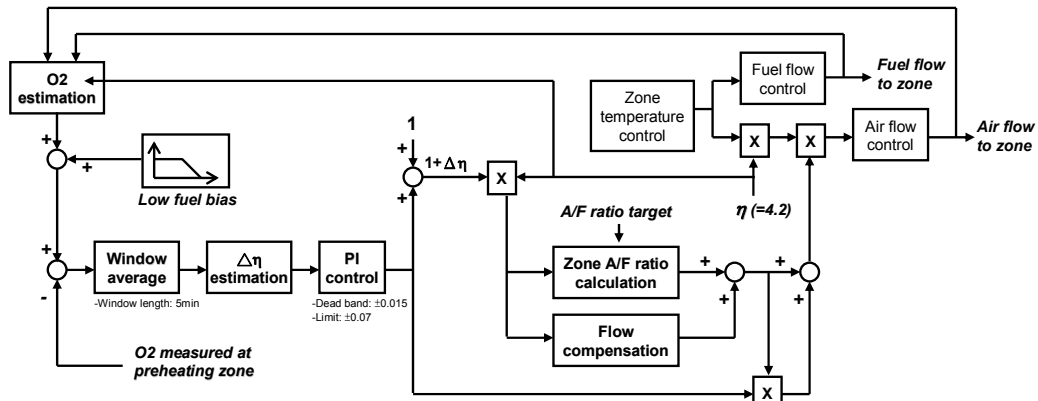

Fig.10. Automatic A/F ratio control at low oxygen concentration.

Figure 13 shows the statistical results of the prediction control in a long-term demonstration. The peak of measured oxygen concentration and the amount of temperature drop are both indices for quantifying the air inhalation during door opening. Although there is no method to measure the air inhalation directly, the positive correlation shown in Fig.13(a) reveals that the two quantitative indices are related to the air inhalation. After using the prediction control, both the averages and standard deviations in the two indices are decreased as shown in Fig.13(b). Also, the lower standard deviation in the two indices means that the prediction control indeed inhibits the air inhaled into the furnace every time the discharging door is opened.

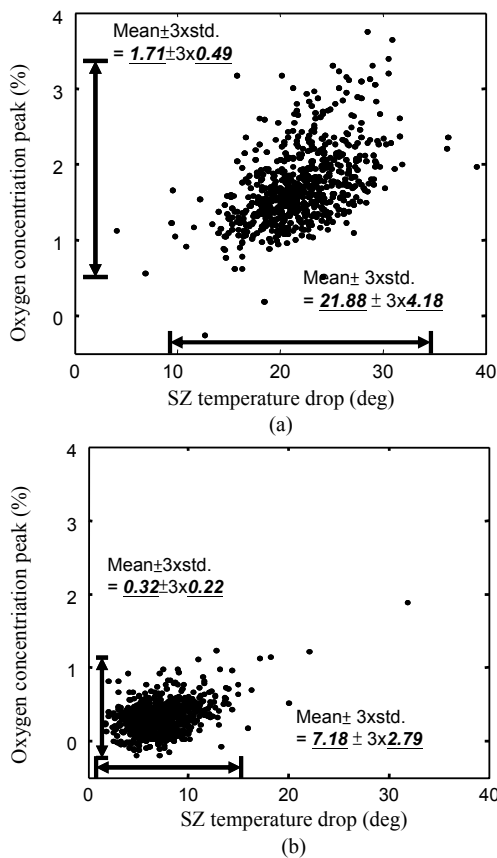

Fig.13. Statistical results of temperature drop and oxygen peak (a)without and (b)with discharging prediction control of furnace pressure.

Figure 14(a) shows the measured oxygen concentration of waste gas before using the low oxygen control. All A/F ratios in the preheating zone, heating zone and soaking zone are fixed, so that any change of fuel heat value or other disturbance may induce a variance of oxygen concentration. Therefore, the A/F ratios were set higher than formerly to ensure the complete combustion of the supplied fuel. However, this inevitably results in an excess of supplied air and causes additional fuel consumption and scale loss. Figure 14(b)

shows the result of low oxygen control. The measured oxygen concentration is more stable and has a significantly small standard deviation, enabling the furnace to remain at a stable low oxygen state. Figure 15 exhibits the statistical results of long-term testing in the four reheating furnaces of No.1 hot strip mill. The results of the trials with low oxygen control all show smaller mean values and standard deviations in oxygen concentration. The trials also demonstrate that the proposed control method is feasible even when the new control used in different furnace.

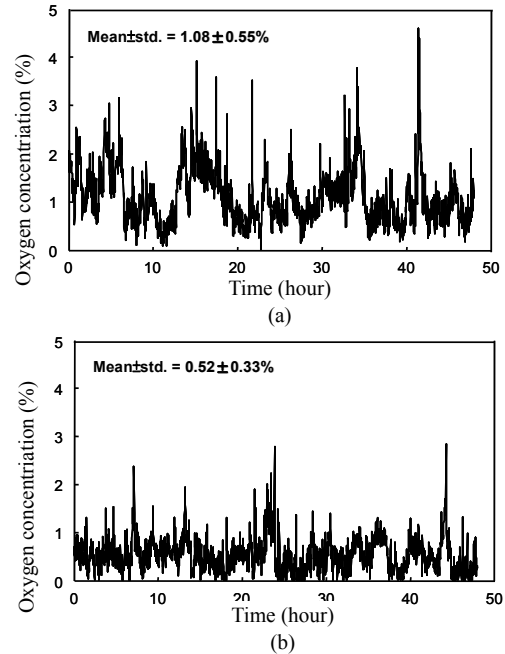

Fig.14. Results of oxygen concentration (a)without and (b)with low oxygen control.

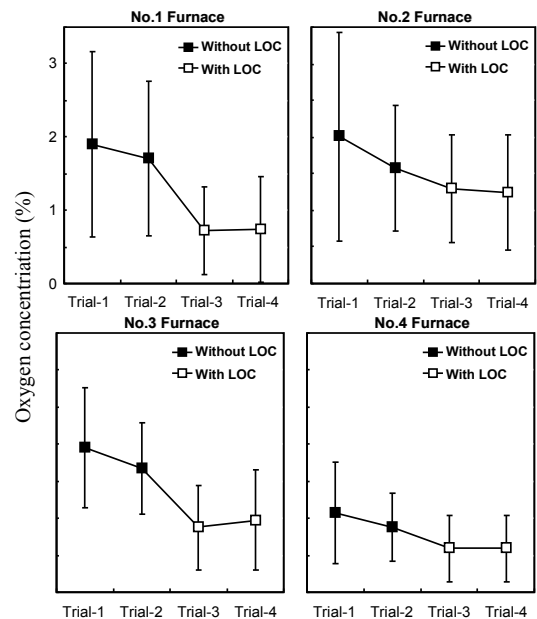

Fig.15. Statistical results of low oxygen control in different furnaces.

Table 1 Benefits of low oxygen control at China Steel

		Fuel consumption	Scale loss
No.1 Hot Strip Mill	No.1 Furnace	3.068%	0.0538%
	No.2 Furnace	-0.241%	0.0422%
	No.3 Furnace	1.218%	0.0541%
	No.4 Furnace	0.498%	0.0199%
No.2 Hot Strip Mill	No.1 Furnace	1.575%	0.0086%
	No.2 Furnace	1.633%	0.0140%
Average		1.292%	0.0321%

To increase the controllability of oxygen content in a furnace atmosphere, the proposed control method in this study first inhibits the air inhalation from the discharging door by using prediction control, and then automatically controls the A/F ratio in each combustion zone via zone A/F calculation, flow compensation and feedback correction. It is important that in the feedback control loop, the control target is not the expected oxygen concentration. The control target is the estimated oxygen concentration calculated according to the measured flow of supplied fuel and air. And, the results demonstrate that this kind of control method is useful to control the oxygen content.

The proposed control method for controlling the oxygen content in a furnace atmosphere has been implemented in the reheating furnaces of No.1 and No.2 hot strip mills at China Steel Corporation. After a total of six furnace testing trials (the results are indicated in Table 1), it is demonstrated that using the control method can have the benefits of saving 1.292% in fuel consumption and increasing the yield by 0.0321%. In other words, when this low oxygen control method is used in the two hot strip mills it is able to annually save about $7.9 \times 10^6 \text{ m}^3$ of C.O.G. consumption, reduce about 2,000 tons of slab scale loss and decrease about 6,000 tons of CO₂ emissions.

4. CONCLUSIONS

In the reheating furnace of a hot rolling mill, thermal energy from fuel combustion heats the slab via heat transfer of radiation and convection. Therefore, the furnace consumes most of the energy and produces high amounts of carbon dioxide in the hot rolling process. The oxygen concentration in the furnace atmosphere is very important because too much oxygen will cause more fuel consumption and will induce more scale on the slab surface and more nitrogen oxides in the combustion gas. Proper control of the oxygen concentration can enable the furnace to obtain a better performance in terms of production cost in energy consumption, slab scale loss, and NO_x emission. There are two sources of oxygen in the furnace atmosphere. One is the combustion air supplied to the burner and

the other is the outside air infiltrated into the furnace during the discharge door opening. Also, the infiltration of cold air will lead to an inconsistent temperature decreasing rate on both sides of the slab and cause a non-uniformity of slab temperature. In this study, a control technology was proposed to inhibit the air infiltration and to minimize the oxygen concentration in the furnace atmosphere by controlling the furnace pressure and combustion air with a prediction method, which could estimate the influence of the variation of combustion loading based on the state change in the control loop. The proposed control method has been implemented in the reheating furnaces of No.1 and No.2 hot strip mills at China Steel Corporation. The results revealed that the control method could significantly inhibit the air infiltration after door opening. Moreover, the oxygen concentration in the furnace atmosphere could be stably minimized by the better control performance. Also, the results of experiments demonstrated that this method could improve the uniformity of slab temperature and reduce the furnace fuel consumption, the scale loss of heated slab, and the thermal NO_x emission.

REFERENCES

1. L.-J. Jiang, J.-G. Jiang, T. Fu, and Y.-J. Yang: Shandong Metallurgy; 2006, vol. 28, no. 2, pp. 24-26.
2. H.-Q. Bai: Journal of Astronautic Metrology and Measurement; 2003, vol. 23, no. 4, pp. 57-62.
3. X.-Y. Liu, J. Sun, and X.-Y. Li: Techniques of Automation & Applications; 2005, vol. 24, no. 9, pp. 75-77.
4. X.-Y. Liu, J.-D. Zhang, and X.-Y. Li: Control Systems; 2006, vol. 22, no. 1-1, pp. 39-40.
5. Z.-Z. Liu, Z.-P. Zheng, C.-J. Ding, H.-S. Zeng, and D.-M. Zhang: Energy for Metallurgical Industry; 2004, vol. 23, no. 2, pp. 30-32.
6. T.-B. Wei: Research on Iron & Steel; 2003, no. 4, pp. 54-58.
7. S.-M. Tao: Baosteel Technology; 2003, no. 3, pp. 38-42. □